

Heathkit of the Month #096:
by Bob Eckweiler, AF6C



ELECTRONIC TEST EQUIPMENT
Heathkit IO-21 3" Oscilloscope

Introduction:

It was the beginning of something big. It might have started in a garage in Los Altos, CA, but it enthralled me in a ham shack in Santa Ana. That was where I first got to play with an Apple][™ computer. It was in the early second half of the 70's, and the shack belonged to fellow club member Ken, W6HHC. Disk drives were still up in the \$600 price range, so programs were stored on, and loaded from, cassette tapes. This beige computer that looked like a typewriter had captured our imaginations, so we surrounded it after many club nets.

Loading programs from cassette tape was tricky. So Ken brought out his trusty Heathkit IO-21 oscilloscope with its 3" CRT¹ screen and used it to monitor the cassette recorder signal to the computer. If the signal had the right amplitude and showed no signs of waveform clipping the program loaded without problem. In those days I wonder if there weren't a lot of scopes hooked up to computers using tape cassette recorders? A successful load depended on having the cassette player volume control set just right for the level the program was originally recorded at. With an oscilloscope it was visually easy to do that.

Here is a link to the index of Heathkit of the Month (HotM) articles:

http://www.w6ze.org/Heathkit/Heathkit_Index.html

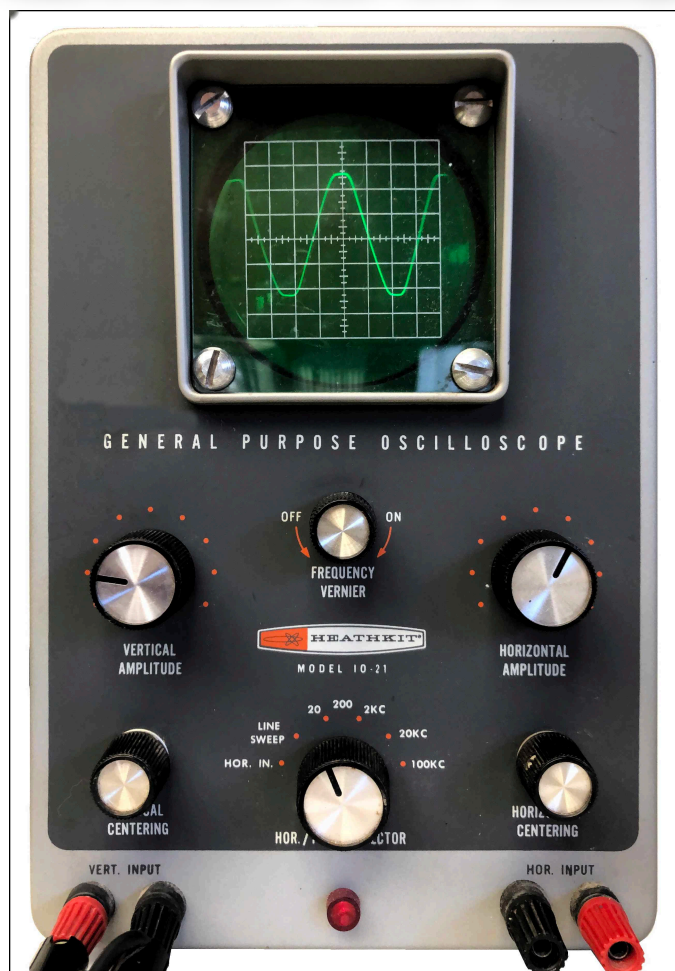

Figure 1: Heathkit IO-21 Oscilloscope

The IO-21 (Figure 1) had some unusual features, but it did a lot of things very well.

The IO-21 3" Oscilloscope History:

The IO-21 first appeared in the Fall Winter 1961 Heathkit catalog² with a "New Through Heath Research" logo appearing near the top of the page. It appeared alongside the more advanced year old 3" IO-10 DC oscilloscope in a two-page spread, each scope taking up one full page with lots of descriptive text and a small image of each schematic. The IO-21 scope was very popular and many were sold over a ten plus year production run. It was not directly replaced, but sold alongside the IO-17 for about three years. The IO-17 con-



tinued to sell for a year after the IO-21 and was the last ³ of the 3-inch CRT oscilloscopes offered by Heathkit. The IO-21 first sold for \$49.95; by 1971 the price had increased to \$61.95 - almost a 25% increase. The IO-21 scope could be bought as part of Heathkit's EF-2-3 **"How to Understand and Use Your Oscilloscope"** course. The 5" IO-12 scope (EF-2-4) and later the 5" IO-18 scope (EF-2-5) were also available with the course.

Heathkit IO-21 & IO-10 Catalog Prices		
Catalog	IO-21	IO-10
Fall Winter 1961	\$49.95	\$79.95
Main 1966	\$54.95	\$89.95
Main 1971	\$61.95	\$99.95

Table I

The IO-21 3" Specifications:

While not a top performer compared with other scopes of the time, The IO-21 has a big advantage of size as well as low cost. Measuring 9-1/2" H x 6-1/2" W x 10" D, it takes up less than half the workbench area of a typical 5" scope. Also, its low height means it is more likely to fit under a shelf above the workbench. With a bandwidth of ± 2 db from 2 cps to 200 KC it has better response than the OL-1 it replaced. The OL-1 is specified at ± 3 db from 2 cps to 200 KC. and ± 6 db from 1 cps to 400 KC. ± 2 db represents a change in trace height of about $\pm 20\%$ while ± 3 db represents a change of about $\pm 29\%$ and ± 6 db represents a change of about $\pm 50\%$.

One improvement over the OL-1 is the CRT used. The OL-1 used a WWII vintage 3GP1. Sometime in the early 60's Heathkit standardized on a new generation 3" CRT, the 3RP1. For their spectrum analyzers like the SB-620 Heath used the high persistence phosphor version, the 3RP7. The 3RP1 and

3RP7 were upgraded with a flat screen and carried an 'A' suffix (3RP1A etc.) that Heathkit used in some of its later products such as the SB-614. The IO-21 was one of Heath's early adopters of the 3RP1 CRT.

The IO-21 is missing some features you would expect on even the simplest beginner scope. First, it has no **intensity** control whatsoever to adjust the trace brightness. It also has no **FOCUS** adjustment on the front panel. The manual specifications says it and the **ASTIGMATISM** ⁴ control are "rear controls", but they are really internal rear controls that require you to remove the cabinet for access. Also there are not any **sync.** adjustment controls. The sweep multivibrator receives a sync signal directly from the vertical amplifier output. The user just adjusts the sweep frequency until the sync locks in, freezing the display. There is no way to switch sync polarity.

Another missing feature is a front panel **TEST** voltage output. This output is often just a low voltage 60-cycle output derived from the filament winding. Even on the simplest of scopes this output is common, and sometimes calibrated to be 1 volt peak-to-peak for calibration purposes. On more expensive scopes it is a calibrated square wave, usually of a higher frequency than 60 cycles.

There is also no attenuator on the vertical input amplifier. The older Heathkit OL-1 scope also lacks a vertical attenuator, though it has front panel **intensity** and **focus** controls as well as a **sync amplitude** control, an **ext. sync** input and a **60 cy test** output.

Surprisingly, the IO-21 scope was used for quite awhile before the missing controls were noticed. Focus, astigmatism and intensity controls, on all but the high end scopes, interact. Fixing the intensity level and hiding the other controls solves that problem. Since



Figure 2: Scope trace showing the lack of retrace blanking. Note the almost horizontal retrace line connecting the trace start to the trace end.

the scope only goes up to 200 KC there is little dimming at high frequencies. Never, while using the scope was there a feeling

that the trace intensity was inadequate. The synchronization was also never a problem. On the plus side this scope has a simple blanking circuit that turns-off the trace as it sweeps back from right to left. This is missing from many of the older, less expensive, scopes including the OL-1. **Figure 2** is a photo of a trace from the earlier Heathkit OL-1 without blanking.

An ASTIGMATISM adjustment is also something not found on many earlier scopes. It requires a capability that is part of the CRT. The war surplus 3GP1 lacks that capability; it is present in the newer 3RP1 series CRTs.

The IO-21 is specified as having identical vertical and horizontal amplifiers, though this is not exactly true. While the differences are minor they are there. That will be discussed later.



Figure 3: A lineup of 14 IO-21 Oscilloscopes undergoing evaluation by a technician at the Heathkit factory. It was customary to have Heath employees build new kits for evaluation. Construction experience data was given to the manual department, and the completed kits were evaluated by technicians for performance. Photo from Gene Fiebich via Chuck Penson.

The IO-21 3" Oscilloscope Controls:

Only six controls, arranged in two rows of three, are on the front panel. Also on the front panel is the CRT face, which is in a bezel with graticule and hood, and two sets of 5-way binding posts, one for vertical and one for horizontal input. A neon pilot lamp provides power indication. Table IA lists the six controls and their markings.

The rear panel has two banana jacks and a slide switch. These allow the user to directly AC couple a signal to the vertical deflection plates. This is handy for monitoring a transmitter's output at frequencies higher than the built-in vertical amplifier can handle. Rear panel controls and connections are listed in Table 1B and shown by Figure 4. When in EXT. external mode the VERTICAL CENTERING control continues to function. Three paper stickers are included in the kit to mark the rear slide switch and its positions.

Two internal 500 KΩ potentiometers adjust the **FOCUS** and **ASTIGMATISM**, and are adjusted for the minimum size round dot. When adjusting these controls, first use a well insulated screwdriver; there is high voltage in the area of these controls. And second, do not allow the spot to remain in one place on the screen too long so you don't damage the CRT's phosphor coating.

The IO-21 Circuit:

The IO-21 ads state the vertical and horizontal amplifiers are "identical", while in the



Figure 4: Heathkit IO-21 Rear Panel

<u>Upper Front Panel</u>	
CRT screen	3" Round
with green graticule	2" x 2"
Divisions - Large 0.25", Small 0.063"	
<u>Upper Control Row (L to R)</u>	
VERTICAL AMPLIFIER gain	Potentiometer 50 KΩ
(9 red dot marks over 340°)	
FREQUENCY VERNIER	Potentiometer 7.5 MΩ
Power OFF Power ON	Switch on Potentiometer
HORIZONTAL AMPLIFIER gain	Potentiometer 20 KΩ
(9 red dot marks over 340°)	
<u>Lower Control Row (L to R)</u>	
VERTICAL CENTERING	Potentiometer 100 KΩ
(no markings)	
HOR./FREQUENCY SELECTOR	6-pos. Rotary Switch
Hor. IN,	
LINE SWEEP.	
20 to 200 cps.	
200 to 2 KC	
2 KC to 20 KC	
20 KC to 100KC	
HORIZONTAL CENTERING	Potentiometer 100 KΩ
(no markings)	
<u>Bottom Terminal Row (L to R)</u>	
VERT. INPUT	
Input	Red Binding Post
Common	Black Binding Post
Pilot Light	Neon bulb
HOR. INPUT	
Common	Black Binding Post
Input	Red Binding Post

TABLE IIA FRONT PANEL CONTROL LAYOUT

<u>Rear Panel Opening (L to R)</u>	
FUSE ↷	Bayonet holder
	½ amp MDL slow blow 3AG (0.25 x 1.25": 6.3 x 32 mm)
	Power Cord with Line Cord Strain Relief
Direct VERT. plate input select	DPDT Slide Switch
INT. - EXT.	
VERT. plate input (pin 7 - D4)	upper black banana jack
	Jacks mounted vertically on ¾" centers on rear panel
VERT. plate input (pin 6 - D3)	lower black banana jack

TABLE IIB REAR PANEL CONTROL LAYOUT

VERT AMP	COMPONENT VALUE	HORIZ AMP	COMPONENT VALUE
R1	2.2 MΩ	R30	<SAME>
R2	1200 Ω	R32	<SAME>
R3	56 KΩ	R31	<SAME>
R4	50 KΩ Pot.	R33	20 KΩ Pot.
R5	100 KΩ	R34	<SAME>
R6	1200 Ω	R35	<SAME>
R7	220K Ω	R36	<SAME>
R8	100 KΩ Pot.	R37	<SAME>
R9	56 KΩ	R38	<SAME>
R10	6800 Ω 2 Watt	R39	<SAME>
R11	22 KΩ 2 Watt	R41	<SAME>
R12	22 KΩ 2 Watt	R40	<SAME>
C1	0.1 μf 200V Paper	C13	<SAME>
C2	2 μf 200V Paper	C14	20 μf 200V Electrolytic
C3	0.002 μf disk ceramic	C15	<SAME>
C4	0.02 μf disk ceramic	C16	<SAME>

TABLE III: Schematic (Figure 5) Component ID and Values for Vertical and Horizontal Amplifiers

manual it states they are *essentially* identical. After looking at the vertical amplifier the differences will be discussed.

Vertical Amplifier:

The vertical amplifier uses a pair of 12AU7 dual triodes. **Figure 5** is a schematic of the vertical amplifier⁵. The first stage, V3A is an AC coupled cathode follower circuit with the bias resistor bootstrapped by R3. This effectively increases the input impedance above the 2.2 MΩ of R1 because of the large in-phase voltage that appears at the junction of R2 and R3 allowing the input resistance to be on the order of 10 MΩ. The output is AC coupled through the VERTICAL AMPLITUDE control to V3B which is a standard voltage amplifier. Its output is DC coupled to the grid of V4A which drives one of the CRT vertical deflection plates (pin 6). V4A signal is also coupled via the common cathode resistor R10 to V4B. The bias for V4B is statically set to a voltage close to the quiescent grid volt-

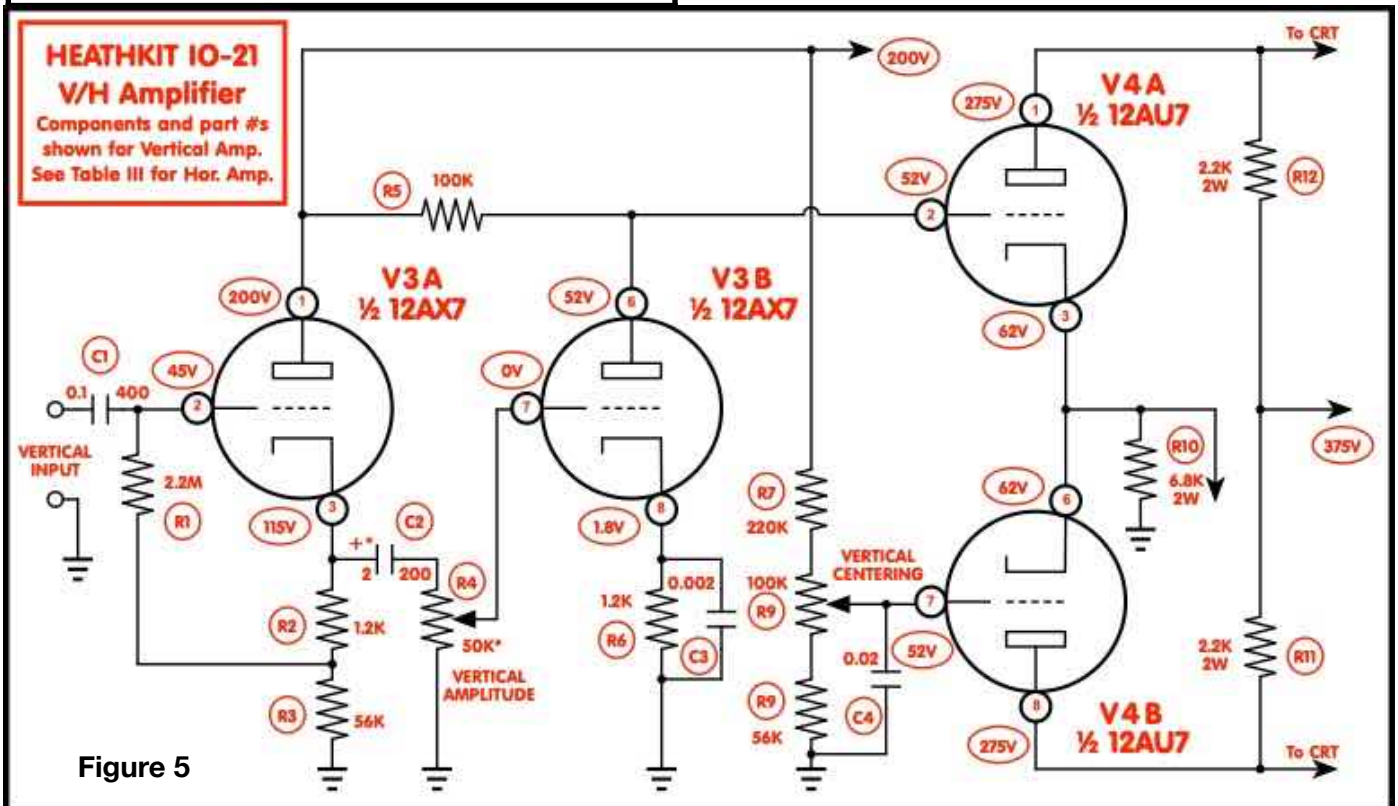

age of V4A. Due to the coupling, the output of V4B is equal, but 180° out of phase, with the output of V4A. This signal is sent to the other CRT vertical deflection plate (pin 7). The bias on V4B can be adjusted by the VERTICAL CENTERING control. This makes one section of the output 12AU7 draw more current and the other less current, effectively moving the trace in the vertical direction. The stages after the initial cathode follower are DC coupled.

Horizontal Amplifier:

The horizontal amplifier is identical except for the coupling between the cathode follower V2A and the voltage amplifier V2B. While the vertical amp uses a 2 μF capacitor with a 50 KΩ VERTICAL AMPLITUDE control, the horizontal amplifier uses a cheaper 20 μF electrolytic capacitor with a 20 KΩ HORIZONTAL AMPLITUDE control. Why the difference? What it does is lower the low-end 3 db frequency response, but the real reason may just be the cost difference of the two capacitors⁶.

Sweep Multivibrator:

The sweep multivibrator circuit is shown in **Figure 6**. The frequency is determined by R22, the FREQUENCY VERNIER control (R23) and a timing capacitor. The timing capacitor is switched with the HOR./FREQUENCY SELECTOR switch, and is one or more of C7, C8, C9 and C20 in series. In Figure 6 it is represented by a single capacitor C_T. R22, R23 and C_T form a parallel RC network.

When V1B turns off, its plate voltage rises sharply turning on V1A and rapidly charging C_T. When C_T reaches near full charge the rising cathode voltage turns V1A off and turns V1B back on, causing the plate voltage at V1B to drop. The pulse that occurs at the V1B plate while it is off is coupled to the CRT cathode through C12 blanking the CRT during retrace.

With V1A off, C_T discharges through R22 and R23. After a partial discharge the voltage at the cathode of V1A drops to the point that it turns on, turning off V1B.

The voltage across C_T is directly connected to the input of the horizontal amplifier when the HOR./FREQUENCY SELECTOR switch is in any of the four sweep positions. When V1A is conducting the rapid charging of C_T draws the spot on the CRT to the left. during this time the CRT is blanked due to the pulse at the plate of V1B. This portion of the sweep is called *RETRACE*. When V1A turns off, C_T starts to discharge, lowering the voltage across

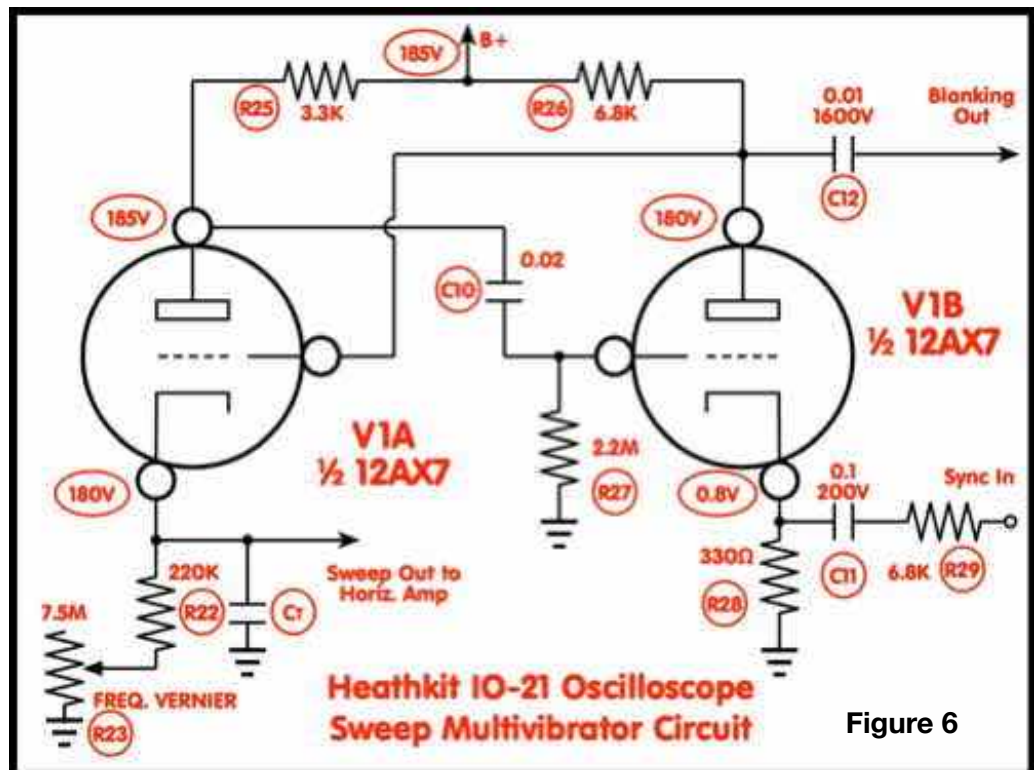

C_T and at the input to the horizontal amplifier. This causes the dot to move right across the screen with blanking off. RC discharge is not linear, but the sweep only uses a few volts of the 180 volt charge, resulting in a reasonably linear sweep.

There are two positions of the HOR./FREQUENCY SELECTOR switch where the sweep multivibrator is not used. The first is

the full CCW position where the horizontal amplifier gets its input from the horizontal input terminals on the front panel and the second is the next switch position where the horizontal amplifier gets its input from a 60 cycle sine wave developed from the 6.3 V filament winding.

Power Supply:

The power supply is conventional. there are two separate 6.3 V filament windings. This is

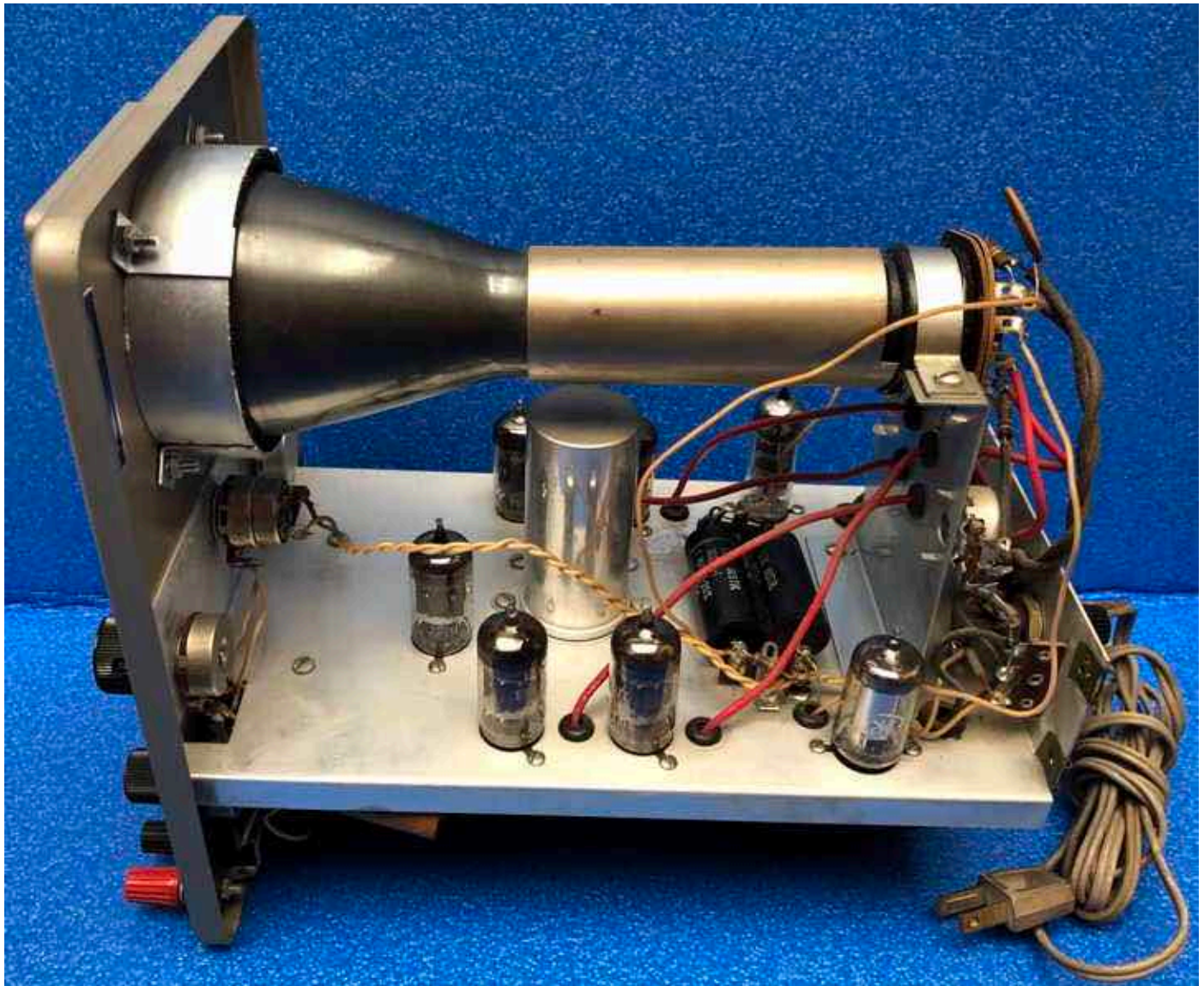

Figure 7: The Heathkit IO-12 out of its cabinet. Note the partial CRT shield on the tube's neck, The three tubes in front are the horizontal amplifier 12AU7s and the 1V2 HV rectifier. The three tubes in the rear are the vertical amplifier 12AU7s and the 6X4 B+ rectifier. The tube closest to the scope front is the 12AX7 sweep multivibrator. The two black capacitors under the CRT neck are the HV filter capacitors. The four red wires going through the rubber grommets are the leads to the CRT deflection plates. They are kept away from the chassis and each other to reduce stray capacitance.

needed to isolate the high voltage on the filament of the CRT.

B+ is supplied by a full wave center tapped transformer winding and a 6X4 rectifier tube. Four voltages are developed. 375 volts for the vertical and horizontal CRT drivers, as well as the astigmatism grids of the CRT; two separate 200 volt outputs, one for each amplifier, and 185 volts for the sweep circuit.

High voltage is obtained from an additional transformer winding added to one of the B+ winding legs. It produces 850 volts and has a filament winding at the top for the 1V2 high-voltage rectifier. After the rectifier and filter, negative 820 volts is available for use by the CRT.

Heathkit IO-21 Assembly:

The IO-21 is one of the rare scopes of the period that does not use one or more printed circuit boards. All wiring is point-to-point. Construction with circuit boards make construction simpler, less error prone and more uniform between units. It is usually less expensive too. Why no circuit board was used in the IO-21 is unknown; the IO-10, sold alongside the IO-21, didn't use a circuit board either. However, the older OL-1 and the IO-17, which was introduced during the run of the IO-21, both use a circuit board.

Construction begins after the builder inventories and becomes familiar with the parts. First, components are mounted on the bottom side of the chassis. These include the



Figure 8: Heathkit IO-21 chassis bottom. photo. Note large power transformer towards rear. 1V2 HV rectifier socket is below the transformer, and 6X4 B+ rectifier is above. Large yellow and brown capacitors are the vertical and horizontal coupling capacitors respectively. Vertical amp is on top; horizontal is on bottom. B+ filter capacitor and sweep multivibrator are in the middle.

seven tube sockets, six three-lug terminal strips (The scope uses a total of nine terminal strips, all are three-lug type with the center lug grounded), five rubber grommets and a can capacitor mounting wafer to which the capacitor is then mounted. The chassis is then turned over and two more terminal strips are mounted to the chassis top.

Next, the front panel is attached to the chassis using three control potentiometers. The fuse holder, banana jacks, slide switch and remaining terminal strip are mounted to the rear of the chassis, and the CRT panel ring with bezel and graticule is mounted to the front panel.

Initial wiring is then begun along with the mounting of the rear CRT support bracket. The remaining front panel components are mounted including the HOR./FREQUENCY SELECTOR switch after its fixed capacitors are install on the switch contacts. The power transformer is then mounted and wired in.

Point-to-point wiring is then done, much of it from a table which shows 31 wire lengths to be cut and where to install them from and to. This is followed by component installation and wiring. Again a similar table is used for many of the resistors.

Final wiring includes adding the few components on the top of the chassis, installing the FOCUS and ASTIGMATISM internal controls to the CRT support bracket, installing the CRT including the CRT socket, and wiring up the socket and a few additional components. The line cord is added last.

Final assembly involves installing the fuse in its holder, adding the handle and feet to the cabinet, constructing a set of test leads and adding the stick on labels to the rear apron. The final steps before checkout is to mount

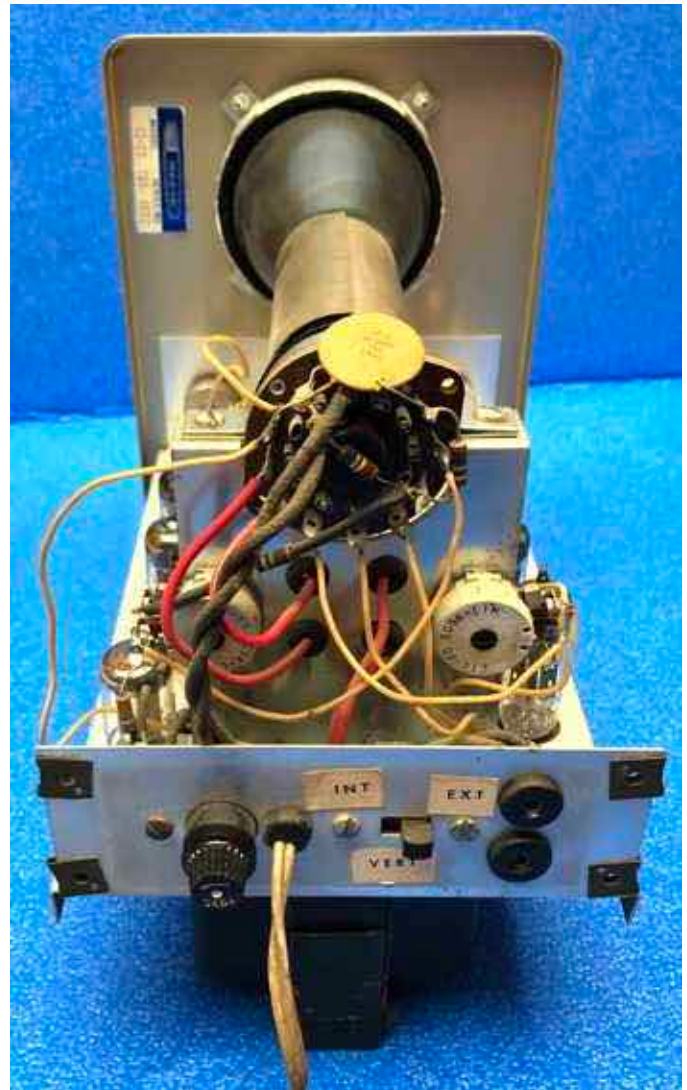

Figure 9: Heathkit IO-21 rear view showing internal FOCUS and ASTIGMATISM controls and CRT socket wiring.

the six front panel knobs and on later models the blue Heathkit series information label.

Heathkit IO-21 Test and Adjustment:

Once completed the scope undergoes a short test and adjustment procedure. As expected with the later Heathkit manuals, the procedure and is given as steps and well thought out. Heath recommends you read through the two plus pages of this section before you start. No test instruments are needed for the checkout, though it will be necessary to have a VTVM or similar meter if you encounter problems. There are three adjustments that

need to be carried out: The first two involve adjusting the internal FOCUS and ASTIGMATISM controls for a small round dot; the third involves rotating the CRT to position the horizontal trace properly. This can be time-consuming as you need to power-down the scope and unplug it before you attempt to rotate the CRT, and it might take numerous iterations to get it aligned to the graticule line. Due to the dangerous high voltage around the CRT socket, don't be tempted to do it with the power on.

Figures 7, 8 and 9 show the insides of the IO-21 oscilloscope and include some comments on the layout. The scope appears to be in the original assembly configuration and hasn't been 'restored' with new capacitors and other components. The scope still works well, with a bright trace and no obvious flaws. This scope was probably later in the production run since it has the Heathkit 'Blue Label' showing the production series and serial number. The manual I purchased from the new Heathkit Company was dated 3/1/63 which was prior to the epoch when Heath began issuing the labels.

The Heathkit Manual:

If you own a Heathkit, even if you don't plan to do any restoration on it, you should have a decent copy of the manual. While some manuals may be found on line, a lot of them are only partial manuals and don't show construction, or are missing other important pages. It is amazing that a lot of people don't think the parts list is worth copying, yet they copy the generic soldering instructions, which appear in almost every man-

ual. Complete manuals are available from numerous sources including the "new" Heathkit Company ⁷ and W7FG's Vintage Manuals ⁸. Ebay is another manual source. A good philosophy is to have a paper manual for each Heathkit you own.

Be aware that kits and manuals can receive updates over the production of a kit. Manuals prior to the early seventies usually have a date, either on the back cover or the table-of-contents page. Sometime in the 70's manual dating was stopped altogether and only the copyright year retained. Around the same time, Heath started putting a dash number after the manual part number which usually starts with a 595-N-V, where N is the multi-digit manual number and V is the manual version dash number. The manual date or dash number changing may or may not indicate a change in the kit and/or manual. Sometimes it is just a reprinting of a manuals without changes. Usually when a design change or manual correction is implemented, it is done with a change sheet included with the manual and the printed manual is not updated until the current manuals are exhausted.

Comments:

The IO-21 is a favorite kit of Chuck Penson WA7ZZE author of three Heathkit books ⁹. It was the first Heathkit he assembled. He has collected a small batch of them, and is currently getting ready to do a major restoration of one of them. While he was driving through Orange County a few years back we met for lunch and he passed along the IO-21 that I used for this article.

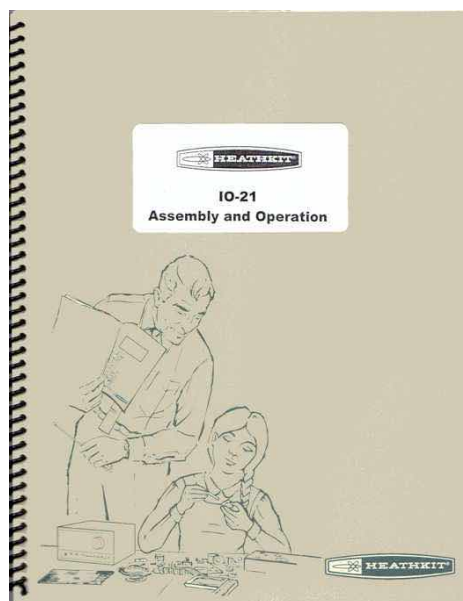

Figure 10: Manual for the IO-21 purchased from the new Heathkit Co.

This is *Heathkit of the Month* article #96. In a few more months the one-hundredth article will appear. After that I plan to slow down a bit and actually spend some time going over past articles and correcting and updating some of them.

The articles are written using Apple© *Pages* software. Originally it was a really good word-processing program which allowed alternating margins and lots of features that were taken advantage of in these articles. Then one day compatibility with the then new iPad became important and *Pages* got an 'update' that took away many of the features these articles incorporate. The pre-updated version continued to be used for awhile until it no longer worked after a system update. This made correcting and updating previous articles difficult to nearly impossible. Documents using alternating margins would not update correctly. Often graphics ended up behind text where they could not be extracted or moved. Word-wrap was also inconsistent between versions making a lot of reformatting necessary.

I have to say Apple has been slowly correcting the problems and restoring features. Now the program is once again viable and I will be able to update the early articles without difficulty - I believe! There is still a problem where graphics that were 'dropped in' during the creation of the original article won't update. There is a work-around for this, though it means more time will still be needed for those cases.

I haven't decided what kit to write about next. I have a simple one, an EUW-18 Laboratory Meter that I've been holding back for when a short article is needed. There is also an IM-4180 FM Deviation Meter sitting on the shelf, complete with manual.

Notes:

1. CRT - Cathode Ray Tube
2. The two-page ad may be found here:
http://www.w6ze.org/Heathkit/Kit_Ads/IO21_10_FW1961.jpg
3. Heath did continue to offer specialized 3" CRT "Vectorscopes" for color TV servicing after 1971.
4. ASTIGMATISM controls the shape of the dot on the CRT. It interacts with the FOCUS control
5. A full schematic of the IO-21 is available at:
<http://www.w6ze.org/Heathkit/Sch/IO-21-Sch.pdf>
6. The 2 µf 200V Mylar capacitor (27-21) cost \$1.15. The 20 µf 150V electrolytic (25-19) cost only 55¢ and works well in the less critical horizontal amplifier.
7. <http://www.heathkit.com>
8. <http://www.vintagemanuals.com>
9. **Heathkit - A Guide to Amateur Radio Products** Oct. 1995 by Chuck Penson WA7ZZE. Second Edition May 2003 Both out-of-print. A Third edition is planned -ISBN 978-0-943016-23-8.

Heathkit Test Equipment Products 2014 by Chuck Penson WA7ZZE - ISBN 978-0-615-99133-7. Available from Amazon.

Heathkit Hi-Fi and Stereo Products Sep. 2018 by Chuck Penson WA7ZZE - ISBN 978-0-692-09843-1. Available from Amazon.

Last month's A-1 Audio Amplifier article was fun to write. A lot of effort went into researching the history. I was saddened that I didn't get any feedback from someone who could provide some of the missing information. There has to be a few still in use or in storage out there?

73, from AF6C



This article is Copyright 2019 R. Eckweiler, AF6C and The OCARC Inc.

Thanks - AF6C